

Uninterruptible power systems (UPS) —

Part 1-1: General and safety requirements for UPS used in operator access areas

The European Standard EN 62040-1-1:2003 has the status of a British Standard

ICS 29.200

National foreword

This British Standard is the official English language version of EN 62040-1-1:2003. It is identical with IEC 62040-1-1:2002, including Corrigendum February 2004. It supersedes BS EN 50091-1-1:1997 which will be withdrawn on 2005-10-01.

The UK participation in its preparation was entrusted to Technical Committee PEL/22, Power electronics, which has the responsibility to:

- aid enquirers to understand the text;
- present to the responsible international/European committee any enquiries on the interpretation, or proposals for change, and keep the UK interests informed;
- monitor related international and European developments and promulgate them in the UK.

A list of organizations represented on this committee can be obtained on request to its secretary.

Cross-references

The British Standards which implement international or European publications referred to in this document may be found in the *BSI Catalogue* under the section entitled “International Standards Correspondence Index”, or by using the “Search” facility of the *BSI Electronic Catalogue* or of British Standards Online.

This publication does not purport to include all the necessary provisions of a contract. Users are responsible for its correct application.

Compliance with a British Standard does not of itself confer immunity from legal obligations.

This British Standard was published under the authority of the Standards Policy and Strategy Committee on 24 February 2003

Summary of pages

This document comprises a front cover, an inside front cover, the EN title page, pages 2 to 44, an inside back cover and a back cover.

The BSI copyright notice displayed in this document indicates when the document was last issued.

Amendments issued since publication

Amd. No.	Date	Comments
15044 Corrigendum No. 1	6 May 2004	Changes to Scope, Normative references, 4.5.3, 4.5.12, 5.5.4, 9, M.5, M.5.1

© BSI 6 May 2004

English version

Uninterruptible power systems (UPS)
Part 1-1: General and safety requirements for UPS
used in operator access areas
(IEC 62040-1-1:2002 + corrigendum 2002 + corrigendum 2004)

Alimentations sans interruption (ASI)
Partie 1-1: Prescriptions générales
et règles de sécurité pour les ASI
utilisées dans des locaux
accessibles aux opérateurs
(CEI 62040-1-1:2002 + corrigendum 2002)
+ corrigendum 2004)

Unterbrechungsfreie
Stromversorgungssysteme (USV)
Teil 1-1: Allgemeine Anforderungen
und Sicherheitsanforderungen
an USV außerhalb abgeschlossener
Betriebsräume
(IEC 62040-1-1:2002 + corrigendum 2002)
+ corrigendum 2004)

This European Standard was approved by CENELEC on 2002-11-01. CENELEC members are bound to comply with the CEN/CENELEC Internal Regulations which stipulate the conditions for giving this European Standard the status of a national standard without any alteration.

Up-to-date lists and bibliographical references concerning such national standards may be obtained on application to the Central Secretariat or to any CENELEC member.

This European Standard exists in three official versions (English, French, German). A version in any other language made by translation under the responsibility of a CENELEC member into its own language and notified to the Central Secretariat has the same status as the official versions.

CENELEC members are the national electrotechnical committees of Austria, Belgium, Czech Republic, Denmark, Finland, France, Germany, Greece, Hungary, Iceland, Ireland, Italy, Luxembourg, Malta, Netherlands, Norway, Portugal, Slovakia, Spain, Sweden, Switzerland and United Kingdom.

CENELEC

European Committee for Electrotechnical Standardization
Comité Européen de Normalisation Electrotechnique
Europäisches Komitee für Elektrotechnische Normung

Central Secretariat: rue de Stassart 35, B - 1050 Brussels

Foreword

The text of document 22H/22/FDIS, future edition 1 of IEC 62040-1-1, prepared by SC 22H, Uninterruptible power systems (UPS), of IEC TC 22, Power electronic systems and equipment, was submitted to the IEC-CENELEC parallel vote and was approved by CENELEC as EN 62040-1-1 on 2002-11-01.

This European Standard supersedes EN 50091-1-1:1996.

The following dates were fixed:

- latest date by which the EN has to be implemented at national level by publication of an identical national standard or by endorsement (dop) 2003-08-01
- latest date by which the national standards conflicting with the EN have to be withdrawn (dow) 2005-11-01

Annexes designated "normative" are part of the body of the standard.

Annexes designated "informative" are given for information only.

In this standard, annexes L, M, N and ZA are normative and annexes H and X are informative.

Annex ZA has been added by CENELEC.

In this standard, the following print types are used:

- Requirements proper and normative annexes: in roman type;
- *Compliance statements and test specifications: in italic type;*
- Notes and other informative matter: in smaller roman type;
- Normative conditions within tables: in smaller roman type;
- Terms that are defined in clause 3: **bold**.

Endorsement notice

The text of the International Standard IEC 62040-1-1:2002 and its corrigendum December 2002 was approved by CENELEC as a European Standard without any modification.

CONTENTS

1	Scope and specific applications	6
1.1	Scope.....	6
1.2	Specific applications.....	6
2	Normative references.....	7
3	Definitions.....	7
3.1	General	7
3.2	UPS electrical ratings	8
3.3	Load types	8
3.4	Connection to the supply	9
3.5	Circuits and circuit characteristics	9
3.6	Insulation	9
3.7	Equipment mobility	9
3.8	Insulation classes of UPS.....	9
3.9	Enclosures	9
3.10	Accessibility	9
3.11	Components.....	9
3.12	Power distribution.....	10
3.13	Flammability.....	10
3.14	Miscellaneous	10
3.15	Telecommunication networks	10
4	General conditions for tests	10
4.1	Operating parameters for tests	10
4.2	Loads for tests	11
4.3	Components.....	11
4.4	Power interfaces	11
4.5	Marking and instructions.....	11
4.5.1	General	11
4.5.2	Power rating	12
4.5.3	Safety instructions	12
4.5.4	Main voltage adjustment.....	13
4.5.5	Power outlets	13
4.5.6	Fuses	13
4.5.7	Wiring terminals	13
4.5.8	Battery terminals	13
4.5.9	Controls and indicators.....	14
4.5.10	Isolation of multiple power sources	14
4.5.11	IT power systems	14
4.5.12	Protection in building installation	14
4.5.13	High leakage current	14
4.5.14	Thermostats and other regulating devices	14
4.5.15	Language	14
4.5.16	Durability of markings.....	14

4.5.17	Removable parts	14
4.5.18	Replaceable batteries	14
4.5.19	Operator access with a tool	15
4.5.20	Battery	15
4.5.21	Installation instructions	16
5	Fundamental design requirements	16
5.1	Protection against electric shock and energy hazards	16
5.1.1	Operator access	16
5.1.2	Access to ELV wiring	16
5.1.3	Discharge of capacitors in the primary circuit	16
5.1.4	Backfeed protection	17
5.1.5	Emergency switching device	17
5.2	Insulation	17
5.3	Limited current circuits	17
5.4	Provisions for protective earthing	18
5.4.1	Protective earthing	18
5.4.2	Bonding	18
5.5	AC and d.c. power isolation	18
5.5.1	Disconnect devices	18
5.5.2	Three-phase equipment	18
5.5.3	Switch as a disconnect	19
5.5.4	Multiple power sources	19
5.5.5	Ungrounded conductors	19
5.6	Overcurrent and earth fault protection	19
5.6.1	Basic requirements	19
5.6.2	Battery circuit protection	20
5.6.3	Location of protective device	20
5.6.4	Rating of protective device	20
5.7	Protection of personnel – Safety interlocks	20
5.7.1	Operator protection	20
5.7.2	Service person protection	21
5.8	Clearances, creepage distances and distances through insulation	22
5.9	External signalling circuits	22
5.10	Limited power source	22
6	Wiring, connections and supply	22
6.1	General	22
6.2	Connection to power	22
6.2.1	Means of connection	22
6.3	Wiring terminals for external power conductors	23
7	Physical requirements	23
7.1	Enclosure	23
7.2	Stability	23
7.3	Mechanical strength	23
7.4	Construction details	24
7.4.1	Openings	24
7.4.2	Gas concentration	24
7.4.3	Equipment movement	24

7.5	Resistance to fire	24
7.6	Battery location	24
7.6.1	Accessibility and maintainability	24
7.6.2	Vibration.....	25
7.6.3	Distance	25
7.6.4	Insulation.....	25
7.6.5	Wiring.....	25
7.6.6	Electrolyte spillage	25
7.6.7	Ventilation	25
7.6.8	Charging voltages.....	26
7.7	Temperature rise.....	26
8	Electrical requirements and simulated abnormal conditions.....	27
8.1	General	27
8.1.1	Earth leakage current	27
8.1.2	Pluggable equipment type B UPS	27
8.2	Electric strength	27
8.3	Abnormal operating and fault conditions.....	27
8.3.1	Simulation of faults	27
8.3.2	Conditions for tests.....	28
9	Connection to telecommunication networks.....	28
Annexes		29
Annex H (informative) Guidance on protection against ingress of water and foreign objects.....		30
Annex L (normative) Backfeed protection test.....		32
Annex M (normative) Examples of reference load conditions		34
Annex N (normative) Ventilation of battery compartments.....		38
Annex X (informative) Guidance for disconnection of batteries during shipment.....		41
Annex ZA (normative) Normative references to international publications with their corresponding European Publication		43
Figure L.1 – Potential load faults		33
Figure X.1 – Precautionary label for products shipped with the battery disconnected		41
Figure X.2 – Precautionary label for products shipped with the battery connected		42
Table 1 – Location of battery protective device(s).....		20
Table 2 – Temperature-rise limits.....		26
Table 3 – Permitted temperature limits for magnetic windings at the end of stored energy mode operation		26
Table H.1 – Degrees of protection against foreign objects indicated by the first characteristic numeral.....		30
Table H.2 – Degrees of protection against water indicated by the second characteristic numeral.....		31

UNINTERRUPTIBLE POWER SYSTEMS (UPS) –

Part 1-1: General and safety requirements for UPS used in operator access areas

1 Scope and specific applications

1.1 Scope

This standard applies to electronic **uninterruptible power systems (UPS)** with an electrical energy storage device in the d.c. link. It is to be used with IEC 60950-1 which is referred to in this standard as "RD".

When any item is referred to by the phrase "The definitions or the provisions of item/RD apply", this phrase is intended to mean that the definitions or provisions in that item of IEC 60950-1 apply, except any which are clearly inapplicable to uninterruptible power systems. National requirements additional to those in IEC 60950-1 apply and are found as notes under relevant clauses of the RD.

The primary function of the **UPS** covered by this standard is to ensure continuity of an alternating power source. The **UPS** may also serve to improve the quality of the power source by keeping it within specified characteristics.

This standard is applicable to **UPS** which are movable, stationary, fixed or for building-in, for use on low-voltage distribution systems and intended to be installed in any **operator** accessible area. It specifies requirements to ensure safety for the **operator** and layman who may come into contact with the equipment and, where specifically stated, for the **service person**.

This standard is intended to ensure the safety of installed **UPS**, both as a single **UPS** unit or as a system of interconnected **UPS** units, subject to installing, operating and maintaining the **UPS** in the manner prescribed by the manufacturer.

This standard does not cover d.c. supplied electronic ballasts (IEC 61347 and IEC 60925), **UPS** intended to be installed in separated electrical locations and **UPS** based on rotating machines.

The relevant general and safety requirements for **UPS** installed in restricted access locations are given in IEC 62040-1-2; electromagnetic compatibility (EMC) requirements and definitions are given in IEC 62040-2.

1.2 Specific applications

Even if this standard does not cover all types of **UPS**, it may be taken as a guide for such equipment. Requirements additional to those specified in this standard may be necessary for specific applications, for example:

- **UPS** intended for operation while exposed, for example, to extremes of temperature; to excessive dust, moisture, or vibration; to flammable gases; to corrosive or explosive atmospheres;
- electromedical applications with the **UPS** located within 1,5 m from the patient contact area;
- for **UPS** subject to transient overvoltages exceeding those for Overvoltage Category II according to IEC 60664, additional protection might be necessary in the mains supply to the **UPS**;

- **UPS** intended for use where ingress of water and foreign objects are possible, additional requirements may be necessary; for guidance on such requirements and for relevant testing, see annex H;
- **UPS** with trapezoidal output waveforms and long run times (greater than 30 min) in addition to complying with 5.3.12 of IEC 62040-3 are subject to voltage distortion tests for the purpose of load compatibility.

NOTE For **UPS** intended to be used in vehicles, on board ships or aircraft, in tropical countries, or on elevations greater than 1 000 m, different requirements may be necessary.

2 Normative references

The following referenced documents are indispensable for the application of this document. For dated references, only the edition cited applies. For undated references, the latest edition of the referenced document (including any amendments) applies.

IEC 60417 (all parts), *Graphical symbols for use on equipment*

IEC 60529:1989, *Degrees of protection provided by enclosures (IP Code)*

IEC 60664 (all parts), *Insulation coordination for equipment within low-voltage systems*

IEC/TR 60755:1983, *General requirements for residual current operated protective devices*
Amendment 1 (1988)
Amendment 2 (1992)

IEC 60950-1:2001, *Information technology equipment – Safety – Part 1: General requirements*

IEC 61000-2-2:2002, *Electromagnetic compatibility (EMC) – Part 2-2: Environment – Compatibility levels for low-frequency conducted disturbances and signalling in public low-voltage power supply systems*

IEC 61008-1:1996, *Residual current operated circuit-breakers without integral overcurrent protection for household and similar uses (RCCBs) – Part 1: General rules*

IEC 61009-1:1996, *Residual current operated circuit-breakers with integral overcurrent protection for household and similar uses (RCBOs) – Part 1: General rules*

IEC 62040-1-2, *Uninterruptible power systems (UPS) – Part 1-2: General and safety requirements for UPS used in restricted access locations*¹⁾

IEC 62040-2:1999, *Uninterruptible power systems (UPS) – Part 2: Electromagnetic compatibility (EMC) requirements*

IEC 62040-3:1999, *Uninterruptible power systems (UPS) – Part 3: Method of specifying the performance and test requirements*

3 Definitions

3.1 General

For the purposes of this standard, the following definitions apply. Where the terms "voltage" and "current" are used, they imply the r.m.s. values, unless otherwise specified.

NOTE Care should be taken that measurement instruments given a true r.m.s. reading in the presence of non-sinusoidal signals.

¹⁾ To be published.

3.1.1

uninterruptible power system (UPS)

combination of convertors, switches and energy storage devices (for example, batteries), constituting a power system for maintaining continuity of load power in case of input power failure

3.1.2

bypass

power path alternative, either internal or external to the **UPS**

3.1.3

primary power

power supplied by an electrical utility company or by a **user's** generator

3.1.4

backfeed

condition in which a voltage or energy available within the **UPS** is fed back to any of the input terminals, either directly or by a leakage path while operating in the **stored energy mode** and with **primary power** not available

3.1.5

backfeed protection

control scheme that reduces the risk of electric shock due to **backfeed**

3.1.6

stored energy mode

operation of the **UPS** when supplied by the following conditions:

- **primary power** is disconnected or is out of a given tolerance;
- battery is being discharged;
- load is within the given range;
- output voltage is within the given tolerance

3.2 UPS electrical ratings

3.2.1

rated voltage

input or output voltage (for three-phase supply, the phase-to-phase voltage) as declared by the manufacturer

3.2.2

rated voltage range

input or output voltage range as declared by the manufacturer, expressed by its lower and upper **rated voltages**

3.2.3

rated current

maximum input or output current of the **UPS** as declared by the manufacturer

3.3 Load types

3.3.1

normal load

mode of operation which approximates as closely as possible the most severe conditions of normal use in accordance with the manufacturer's operating instructions. However, when the conditions of actual use can obviously be more severe than the maximum load conditions recommended by the manufacturer, a load shall be used that is representative of the maximum that can be applied

NOTE For examples of reference **normal load** conditions for **UPS**, see annex M.

3.3.2

linear load

load where the current drawn from the supply is defined by the relationship:

$$I = U/Z$$

where

I is the load current;

U is the supply voltage;

Z is the load impedance

3.3.3

non-linear load

load where the parameter Z (load impedance) is no longer a constant but is a variable dependent on other parameters, such as voltage or time (see annex M)

3.4 Connection to the supply

The definitions of 1.2.5/RD apply together with the following.

3.4.1

power cord

flexible cord or cable for interconnection purposes

3.5 Circuits and circuit characteristics

The definitions of 1.2.8/RD apply.

3.5.1

hazardous voltage

The definitions in 1.2.8.5/RD apply.

3.6 Insulation

The definitions of 1.2.9/RD apply.

3.7 Equipment mobility

The definitions of 1.2.3/RD apply.

3.8 Insulation classes of UPS

The definitions of 1.2.4/RD apply.

3.9 Enclosures

The definitions of 1.2.6/RD apply.

3.10 Accessibility

The definitions of 1.2.7/RD apply.

3.11 Components

The definitions of 1.2.11/RD apply.

3.12 Power distribution

The definitions of 1.2.8/RD apply.

3.13 Flammability

The definitions of 1.2.12/RD apply.

3.14 Miscellaneous

The definitions of 1.2.13/RD apply together with the following.

3.14.1 type test

The definition of 1.4.2/RD applies together with the following addition.

Where in this standard compliance of materials, components or subassemblies is checked by inspection or by testing of properties, it is permitted to confirm compliance by reviewing any relevant data or previous test results that are available instead of carrying out the specified **type tests**.

NOTE For physically large units and/or power ratings, adequate test facilities to demonstrate some of the **type tests** may not exist.

This situation also applies to some electrical tests for which no commercial test simulation equipment is available or requires specialized test facilities beyond the scope of the manufacturer's premises.

3.15 Telecommunication networks

The following definitions apply:

1.2.8.9/RD, 1.2.8.10/RD, 1.2.8.11/RD, 1.2.8.12/RD, 1.2.13.8/RD

4 General conditions for tests

The provisions of 1.4.1/RD, 1.4.2/RD, 1.4.3/RD, 1.4.6/RD, 1.4.7/RD, 1.4.8/RD, 1.4.10/RD, 1.4.11/RD, 1.4.12/RD, 1.4.13/RD, 1.4.14/RD apply together with the following.

Only the leakage current and heating tests shall be performed at input voltage tolerances. All other tests shall be run at nominal input voltages.

4.1 Operating parameters for tests

Except where specific test conditions are stated elsewhere in the standard, and where it is clear that there is a significant impact on the results of the test, the tests shall be carried out under the most unfavourable combination of the following parameters, within the manufacturer's operating specifications:

- supply voltage;
- absence of supply voltage;
- supply frequency;
- charge condition of the battery;
- physical location of **UPS** and position of movable parts;
- operating mode;

- adjustments of **thermostats**, regulating devices or similar controls in **operator access areas**, which are
 - a) adjustable without the use of a **tool**, or
 - b) adjustable using a means, such as a key or a **tool**, deliberately provided for the **operator**.

4.2 Loads for tests

In determination of input current, and where other test results could be affected, the following variables shall be considered and adjusted to give the most unfavourable results:

- loads due to recharging of batteries;
- loads due to optional features, offered or provided for by the manufacturer for inclusion in or with the equipment under test;
- loads due to other units of equipment intended by the manufacturer to draw power from the equipment under test;
- loads that could be connected to any standard supply outlets in **operator access areas** on the equipment, up to the value indicated in the marking required by 4.5.2.

Artificial loads may be used to simulate such loads during testing.

4.3 Components

The provisions of 1.5.1/RD, 1.5.2/RD, 1.5.4/RD, 1.5.5/RD, 1.5.6/RD, 1.5.7/RD, 1.5.8/RD apply.

4.4 Power interfaces

The provisions of 1.6.1/RD, 1.6.2/RD, 1.6.4/RD apply together with the following.

The neutral conductors, if any, shall be insulated from earth and the body throughout the equipment, as if they were a phase conductor. Components connected between neutral and earth shall be rated for a **working voltage** equal to the phase-to-neutral voltage. In the case of the output neutral conductor being isolated from the input neutral conductor, the **service person** responsible for the installation shall connect this output neutral conductor as required by local wiring rules and as detailed in the installation instructions.

Compliance is checked by inspection.

4.5 Marking and instructions

4.5.1 General

Where a marking is required as detailed below, provision shall be allowed for equivalent wording. For equipment intended to be installed by anyone other than a **service person**, the marking shall be readily visible either in an **operator access area** or shall be located on an outside surface of the equipment. If located on an outside surface of fixed equipment, the marking shall be visible after the equipment has been installed as in normal use.

Markings that are not visible from the outside of the equipment are considered to be in compliance if they are directly visible when opening a door or cover. If the area behind a door or cover is not an **operator access area**, a readily visible marker shall be attached to the equipment to clearly indicate the location of the marking; it is allowed to use a temporary marker.

4.5.2 Power rating

Equipment shall be provided with adequate markings in order to specify

- input supply requirements,
- output supply ratings.

For equipment with multiple **rated voltages**, the corresponding **rated currents** shall be marked such that the different current ratings are separated by a solidus (/) and the relation between **rated voltage** and associated **rated current** appears distinctly.

Equipment with a **rated voltage range** shall be marked with either the maximum **rated current** or with the current range.

The markings of input and output shall include those in the RD, in addition to the following:

- output **rated voltage**;
- output **rated current** or rated power in volt-amperes or active power in watts;
- output rated power factor, if less than unity, or active power and apparent power or active power and **rated current**;
- number of output phases ($1\phi - 3\phi$) with or without neutral;
- output rated active power, in watts or kilowatts according to annex M;
- output rated apparent power in volt-amperes or kilovoltamperes according to annex M;
- maximum ambient operating temperature range (optional).

NOTE Compliance according to annex M.

For units designed with additional separate automatic **bypass/maintenance bypass**, additional input a.c. supply, or external batteries, it shall be allowed for relevant supply ratings to be specified in the accompanying installation instructions. Where this is done, the following instruction shall appear on or near the point of connection.

SEE INSTALLATION INSTRUCTIONS BEFORE CONNECTING TO THE SUPPLY

If a unit is not provided with a means for direct connection to the supply mains, it need not be marked with its **rated current**.

4.5.3 Safety instructions

It is necessary to take special precautions to avoid the introduction of hazards when operating, installing, maintaining, transporting or storing **UPS**; the manufacturer shall make available the necessary instructions.

NOTE 1 Special precautions may be necessary, for example, for battery connection of the equipment to the supply and the interconnection of separate units, if any. The protective connection of the **UPS**, of the battery cabinet and terminals or outlets for equipment supplied by **UPS** should remain interconnected even when the mains plug of the **UPS** is disconnected.

NOTE 2 Where appropriate, installation instructions should include reference to national wiring rules.

NOTE 3 Maintenance information is normally made available only to **service persons**.

The operating instructions and, for pluggable equipment intended for **user** installation, the installation instructions shall be made available to the **user**.

The manufacturer shall provide the **user** with guidance on the level of competence necessary for installation, for example:

- **operator** installable: any **pluggable type A** or **pluggable type B equipment** with battery already installed by the supplier;
- **service person** installable: any fixed equipment or equipment with batteries not installed when delivered to the **user**.

The manufacturer shall provide the **user** with guidance on the level of competence necessary to operate the equipment as

- operated by laymen;
- operated by experienced personnel.

When the disconnect device for isolation of mains power is not incorporated in the equipment (see 3.4.2/RD) or when the plug on the power supply cord is intended to serve as the disconnect device, the installation instructions shall state that

- for **permanently connected equipment**, an appropriate and readily accessible disconnect device shall be incorporated in the fixed wiring;
- for pluggable **UPS**, the mains socket outlet that supplies the **UPS** shall be installed near the **UPS** and shall be easily accessible. When the **UPS power cord** must be connected to an earthed mains socket outlet for safety reasons, the **UPS** marking or installation instructions shall so state; the same requirement for marking applies to any special equipotential earth bonding to other connected **UPS** equipment or Class I loads.

NOTE 4 Pluggable **power cords** are normally 2 m in length or less.

For permanently connected **UPS** without internal automatic **backfeed** isolation (see 5.1.4), the instructions shall require the fitting by the **user** of a warning label on all **primary power** isolators installed remote from the **UPS** area, to warn electrical maintenance personnel that the circuit feeds a **UPS**.

The warning label shall carry the following wording or equivalent.

**ISOLATE UNINTERRUPTIBLE POWER SUPPLY (UPS)
BEFORE WORKING ON THIS CIRCUIT**

4.5.4 Main voltage adjustment

See 1.7.4/RD.

4.5.5 Power outlets

See 1.7.5/RD.

4.5.6 Fuses

See 1.7.6/RD.

4.5.7 Wiring terminals

See 1.7.7/RD.

4.5.8 Battery terminals

Terminals intended for connection to batteries shall indicate the polarity according to IEC 60417 or be so constructed as to reduce the likelihood of improper connection.

4.5.9 Controls and indicators

See 1.7.8/RD.

4.5.10 Isolation of multiple power sources

See 1.7.9/RD.

4.5.11 IT power systems

See 1.7.10/RD.

4.5.12 Protection in building installation

If **pluggable equipment type B** or **permanently connected equipment** relies on the building installation for the protection of internal wiring of the equipment, the equipment installation instructions shall so state and shall also specify the necessary requirements for short-circuit protection or overcurrent protection or, where necessary, for both (see 5.6.1).

If the protection against electric shock of the **UPS** (5.1) relies on residual current devices in the building installation circuit and the design of the **UPS** is such that in any normal or abnormal operating condition a fault current to earth with d.c. component is possible, the installation instructions shall define the building residual current devices as type B (IEC/TR 60755/A2) for three-phase **UPS** and as type A (IEC 61008-1 or IEC 61009-1) for single-phase **UPS**.

NOTE Consideration should be given to national wiring rules, if any, regarding requirements for public networks protection.

4.5.13 High leakage current

See 5.1/RD. In addition, the following provisions apply.

For **UPS** systems intended for use as **pluggable equipment type B** or fixed installations, where the earth leakage currents of the **UPS** and connected loads sum in the primary **UPS** protective earth conductor exceeds or is likely to exceed the limits of 5.1/RD under any mode of operation, the unit shall carry a warning label as required by 5.1/RD, and the installation manual shall define the connection method to the **primary power** source.

4.5.14 Thermostats and other regulating devices

See 1.7.11/RD.

4.5.15 Language

See 1.7.12/RD.

4.5.16 Durability of markings

See 1.7.13/RD.

4.5.17 Removable parts

See 1.7.14/RD.

4.5.18 Replaceable batteries

See 1.7.15/RD.

4.5.19 Operator access with a tool

See 1.7.16/RD.

4.5.20 Battery

External battery cabinets or battery compartments within the **UPS** shall be provided with the following, clearly legible information in such a position as to be immediately seen by a **service person** when servicing the **UPS**, in accordance with the requirements of 1.7.1/RD:

- a) battery type (lead-acid, NiCd, etc.) and number of blocks or cells;
- b) nominal voltage of total battery;
- c) nominal capacity of total battery (optional);
- d) warning label denoting an energy or electrical shock and chemical hazard and reference to the maintenance handling and disposal requirements detailed in the following instructions.

Exception: **Pluggable equipment type A UPS**, supplied with integral batteries or with separate battery cabinets, intended for location either under or over or alongside the **UPS**, connected by plugs and sockets for **operator** installation, need only be fitted with the warning label (see item d above) on the outside of the unit.

All other information shall be given in the **users'** instructions.

Instructions

- a) Internally mounted battery:
 - instructions shall carry sufficient information to enable the replacement of the battery with a suitable recommended type;
 - safety instructions to allow access by a **service person** shall be stated in the installation/service handbook;
 - if batteries are to be installed by a **service person**, instructions for interconnections including terminal torques shall be provided.

The operator manual shall include the following instructions:

- Servicing of batteries should be performed or supervised by personnel knowledgeable about batteries and required precautions.
- When replacing batteries, replace with the same type and number of batteries or battery packs.

CAUTION: Do not dispose of batteries in a fire. The batteries may explode.

CAUTION: Do not open or mutilate batteries. Released electrolyte is harmful to the skin and eyes. It may be toxic.

- b) Externally mounted batteries:
 - installation instructions shall state voltage, ampere-hour rating, charging regime and method of protection required on installation to coordinate with **UPS** protective devices, where the battery is not provided by the **UPS** manufacturer;
 - instructions for the battery cells shall be provided by the battery manufacturer.
- c) External battery cabinets:

External battery cabinet supplied with the **UPS** shall have adequate installation instructions to define cable sizes for connection to the **UPS** if the cabling is not supplied by the **UPS** manufacturer. Where the battery cells or blocks are not supplied pre-installed and wired, installation instructions for the battery cells or blocks shall be provided by the battery manufacturer, if not detailed in the **UPS** manufacturer's installation instructions.

4.5.21 Installation instructions

Adequate information shall be provided in the installation instructions as to the purpose and connection of any signalling circuits, relay contacts, Emergency Power Off (EPO) circuits, etc. Attention should be drawn as to the necessity of maintaining characteristics of any **TNV**, **SELV** or **ELV circuits** when connected to other equipment.

Installation instructions shall carry sufficient information, including the basic internal circuit configuration of the **UPS**, to emphasize its compatibility to power distribution systems.

Special attention shall be given to the compatibility with the relevant wiring rules and to **bypass** circuits.

5 Fundamental design requirements

5.1 Protection against electric shock and energy hazards

The provisions of 2.1.1.2/RD, 2.1.1.4/RD, 2.1.1.5/RD, 2.1.1.6/RD, 2.1.1.7/RD apply together with the following.

5.1.1 Operator access

The standard specifies two categories of requirements for protection against electric shock from energized parts. Additional requirements for protection against energy hazards are specified in 2.1.1.5/RD.

NOTE 1 For **SELV circuit** definition, see 1.2.8.7/RD.

The two categories of requirements are based on the following principles.

a) The **operator** is permitted to have access to

- bare parts in **SELV circuits**;
- bare parts in **limited current circuits**;
- insulation of wiring in **ELV circuits** under the conditions specified in 2.1.1.3/RD.

NOTE 2 Attention should be given to access to bare conductive parts at a voltage level of 25 V to 50 V a.c. and 60 V to 120 V d.c.

b) The **operator** shall be prevented from having access to

- bare parts of circuits at **ELV** or **hazardous voltages**,
- operational or **basic insulation** of such parts except under the conditions specified in 5.1.2;
- unearthed conductive parts separated from parts at **ELV** or at **hazardous voltages** by operational or **basic insulation** only.

5.1.2 Access to ELV wiring

Subclause 2.1.1.3/RD applies together with the following.

NOTE Consideration should be given to the maximum unsynchronized voltages or an unsynchronized condition at the inverter.

Compliance is checked by inspection and, if necessary, by test.

5.1.3 Discharge of capacitors in the primary circuit

Subclause 2.1.1.7/RD applies together with the following.

NOTE Attention is drawn to the fact that when loads are connected to the **UPS**, for certain configurations, the risk of electric shock is not only due to the internal capacitors of the **UPS** but also to the capacitors of the load connected to the **UPS**. This should be taken into account when designing the installation.

5.1.4 Backfeed protection

Backfeed protection shall be provided. Electric shock hazard (**hazardous voltage, hazardous energy**, hazardous touch current) shall not appear on the input of the backfeed protecting device under normal condition and condition of a single fault on a component (such as in the control circuit) upon loss of the a.c. input voltage.

For fixed installation UPS, backfeed protection may be provided internally or externally to the UPS in the a.c. input line.

When backfeed protection isolator is external to the UPS, the supplier shall specify the type of the suitable isolating device which shall be used.

A label shall be provided close to the input terminals (see 4.5.3).

Compliance is checked by test and inspection of the equipment and relevant circuit diagram and by simulating fault conditions according to 5.3/RD

If the **backfeed protection** employs an air gap, the air gap shall be defined by the following or equivalent.

- a) Under normal operation the space between poles of phases must meet the requirements for **basic insulation** (see tables 2K and 2L/RD).
- b) If the unit is operating on inverter, the source is considered to be a secondary supply which is transient free (see table 2K/RD, last column). For example, circuits with voltage less than 150 V r.m.s. require 0,7 mm for **basic insulation** and circuits with voltage greater than 150 V r.m.s. but less than 300 V r.m.s. require 1,4 mm for **basic insulation**. For a **UPS** with floating outputs, opening all phases and the neutral using the required **clearance** for **basic insulation** is considered acceptable. If the output is grounded to the chassis, then **reinforced insulation** or equivalent is required.
- c) **Clearances** for components may be further reduced provided they meet both the manufacturing quality control programme that has at least the same level of quality assurance as the example given in clause R.2/RD and withstand voltage of table G.2/RD. For example, 0,4 mm is an acceptable air gap for voltages not exceeding 300 V r.m.s.

Compliance is checked by inspection.

5.1.5 Emergency switching device

A **UPS** shall be provided with an integral single emergency switching device (or terminals for the connection of the remote emergency switching device), which prevents further supply to the load by the **UPS** in any mode of operation. If reliance is placed on additional disconnection of supplies in the building wiring installation, the installation instructions shall so state.

The requirement is not mandatory for pluggable **UPS** if permitted by national wiring rules and relevant circuit diagrams.

Compliance is checked by inspection.

5.2 Insulation

The provisions of 2.2.3.1/RD, 2.2.3.2/RD and 2.2.3.3/RD apply.

5.3 Limited current circuits

The provisions of 2.4.1/RD, 2.4.2/RD, 2.4.3/RD apply.

5.4 Provisions for protective earthing

The provisions of 2.6/RD apply together with the following.

5.4.1 Protective earthing

Accessible conductive parts of **Class I equipment**, which might assume a **hazardous voltage** in the event of a single insulation fault, shall be reliably connected to a protective earthing terminal within the equipment.

This requirement does not apply to accessible conductive parts that are separated from parts at **hazardous voltage** by

- earthed metal parts, or
- solid insulation or an air gap, or a combination of the two, meeting the requirements for **double insulation** or **reinforced insulation**. In this case the parts involved shall be so fixed and so rigid that the minimum distances are maintained during the application of force as required by the relevant tests of 2.10/RD and 4.2.3/RD.

Compliance is checked by inspection and by the applicable requirements of 2.6.1/RD and 5.3/RD.

5.4.2 Bonding

For **Class I pluggable equipment type A**, the **UPS** shall provide sufficient terminals, earthed socket-outlets or other means to permit, in the final installed system configuration, equipotential earth bonding to the **UPS** from other **Class I equipments**, including external **UPS** battery cabinets, irrespective of whether the **UPS** primary protective conductor is disconnected from its source. Any special bonding instructions shall be stated in the **user's instructions**.

Compliance is checked by inspection and earth resistance tests between respective connection points.

5.5 AC and d.c. power isolation

The provisions of 2.6.2/RD, 2.6.3/RD, 2.6.4/RD, 2.6.5/RD apply together with the following.

5.5.1 Disconnect devices

Disconnection devices shall be provided to disconnect the **UPS** from the a.c. supplies for servicing by qualified personnel.

NOTE Unless required for functional use, the means of isolation can be located either in the **service access area** or external to the equipment.

5.5.2 Three-phase equipment

For three-phase **UPS**, the disconnect device(s) shall disconnect simultaneously all phase conductors of the supply. The **UPS** requiring a neutral connection to an IT power system, the disconnect device shall be a four-pole device and shall disconnect all phase conductors and the neutral conductor. If this four-pole device is not provided in the **UPS**, the installation instructions shall specify the need for its provision as part of the building installation.

If a disconnect device interrupts the neutral conductor, it shall simultaneously interrupt all phase conductors (see 1.7.2/RD).

5.5.3 Switch as a disconnect

Where the disconnect device is a switch incorporated in the equipment, its "ON" and "OFF" positions shall be marked in accordance with 1.7.8/RD.

If the operating means of the disconnection device is operated vertically rather than rotationally or horizontally, the "UP" position of the operating means shall be the "ON" position.

5.5.4 Multiple power sources

Where a permanently connected unit receives power from more than one external source (for example, from different voltages/frequencies as redundant power), there shall be a prominent marking at each disconnect device giving adequate instructions for the removal of all power from the unit.

NOTE Attention should also be paid to the PE conductor(s) so that the PE-connection remains even if one of the supply cables is removed.

5.5.5 Ungrounded conductors

For both internal and external d.c. battery supplies, disconnect devices or means of isolation shall open all ungrounded conductors of the battery or batteries.

Compliance with 5.5 is checked by inspection.

5.6 Overcurrent and earth fault protection

The provisions of 2.7.3/RD, 2.7.4/RD, 2.7.5/RD, 2.7.6/RD apply together with the following.

5.6.1 Basic requirements

Protection against excess currents, short circuits and earth faults in input and output circuits shall be provided, either as an integral part of the equipment or as part of the building installation.

- a) Except as detailed in item b), protective devices necessary to comply with the requirements of 8.3 shall be included as integral parts of the equipment.
- b) For components in series with the mains input to the equipment, such as the supply cord, appliance coupler, RFI filter, **bypass** and switches, short-circuit and earth-fault protection shall be provided by protective devices in the building installation.
- c) If reliance is placed on protection in the building installation, the installation instructions shall comply with 4.5.12 except that for **pluggable equipment type A**, the building's installation shall be regarded as providing protection in accordance with the rating of the socket and 4.5.12 does not apply.
- d) The manufacturer shall specify the r.m.s. value of the available fault current under the most unfavourable conditions to allow the correct dimensioning of the neutral, protection and phase conductors for permanently connected output circuits. The fault current need not be provided if the manufacturer provides output circuit protection or for **pluggable equipment type A** outputs.

When the inverter output current is controlled solely by a current limiting circuit, the available short-circuit current or overload current shall not produce a hazard within the meaning of this standard.

The protection from short circuits shall operate within 5 s.

NOTE The purpose of the above requirement is to reduce the risk of electric shock or fire hazard during the period of an output short circuit. Providing a breaker at the output, rated the same as the output circuit, or current limiting, at the same rating, is considered sufficient to meet this requirement.

Compliance is checked by inspection and functional test.

5.6.2 Battery circuit protection

A battery supply circuit shall be provided with overcurrent protection complying with the requirements described in 5.6.3, 5.6.4 and table 1.

5.6.3 Location of protective device

Where the batteries are installed inside the **UPS**, the battery supply circuit shall be provided with a protective device located adjacent to the battery connecting means before any component which may fail short-circuited, such as capacitors, semi-conductors, or similar components.

Where the batteries are installed outside the **UPS**, the location of the overcurrent protective device shall be as indicated in table 1.

Table 1 – Location of battery protective device(s)

Location and/or type of battery supply	Location	Number of devices Overcurrent	Number of devices Earth faults
1) Within UPS	UPS	1	1 or 2 ^a
2) Movable or stationary separate cabinet	Battery cabinet	1	1 or 2 ^a
3) Fixed separate cabinet	Battery cabinet	1	1 or 2 ^a
4) Separate battery room ^b	Battery room	1	1 or 2 ^a
^a Earth faults on ungrounded batteries require a device in each pole unless external circuit fusing serves the same purpose. ^b The instruction manual for a UPS shall state the rating of the overcurrent device(s) to coordinate with the UPS and associated cabling. This shall apply also for items 2 and 3 if such cabinets are not supplied with the UPS as a complete system.			

For a **UPS** to be used with a separate battery supply, the rating of the overcurrent protective device shall be indicated in the instruction manual and shall take into account the current rating of the conductors to be connected between the **UPS** and battery supply, as determined from the requirement given in 6.2.

5.6.4 Rating of protective device

The rating of the overcurrent protective device located internally shall be such as to protect against conditions described in 5.3.1/RD.

Compliance with 5.6 is checked by inspection and tests.

5.7 Protection of personnel – Safety interlocks

5.7.1 Operator protection

To areas where **operators** have access, the provisions of 2.8/RD **safety interlocks**, apply.

5.7.2 Service person protection

In addition to the requirements of 2.8/RD, the following subclauses apply to **service persons** who find it necessary to reach over, under, across and around an uninsulated electrical part or moving part to make adjustments or measurements while the **UPS** is energized.

5.7.2.1 Covers

Parts at **hazardous voltage** or energy level shall be so arranged and covers so located as to reduce the risk of electric shock or high current levels while covers are being removed and replaced.

5.7.2.2 Location and guarding of parts

Parts at **hazardous voltage** or energy level and moving parts that involve a risk of injury to persons shall be located, guarded or enclosed so as to reduce the likelihood of unintentional contact by a **service person** adjusting or resetting controls, or the like, or performing mechanical functions that may be performed with the **UPS** energized such as lubricating a motor, adjusting the setting of a control with or without marked dial settings, resetting a trip mechanism or operating a manual switch.

5.7.2.3 Parts on doors

Parts at **hazardous voltage** or energy level, located on the rear side of a door, shall be guarded or insulated to reduce the likelihood of unintentional contact of the live parts by a **service person**.

Compliance with 5.7.1 to 5.7.2.3 is checked by inspection, measurement and use of the test finger (figure 2A/RD).

5.7.2.4 Component access

A component that requires inspection, resetting, adjustment, servicing or maintenance while energized shall be so located and mounted with respect to other components and with respect to grounded metal parts that it is accessible for electrical service functions without subjecting the **service person** to the risk of electric shock, **hazardous energy level**, high current or injury to person by adjacent moving parts. Access to a component shall not be impeded by other components or wiring.

For an adjustment that is to be made with a screwdriver or similar **tool** when the **UPS** is energized, the requirement in 2.8.3/RD necessitates that protection be provided so that inadvertent contact with adjacent uninsulated hazardous live parts involving a risk of electric shock or **hazardous energy level** is unlikely, taking into consideration that misalignment of the **tool** with the adjustment can result when an adjustment is attempted.

This protection shall be provided by

- location of the adjustment means away from uninsulated hazardous live parts, or
- a guard to reduce the likelihood of the **tool** from contacting uninsulated live parts.

Compliance is checked by inspection and, where necessary, by fault simulation.

5.7.2.5 Moving parts

Moving parts that can cause injury to persons during service operations shall be located or protected so that unintentional contact with the moving parts is not likely.

5.7.2.6 Capacitor banks

Capacitor banks shall be fitted with a means of discharge for protection of **service persons**. A warning label shall be added if discharge time exceeds 1,0 s, stating the time taken to reduce the hazard to a safe level (not greater than 5 min) (see 1.2.8.4/RD and 1.2.8.7/RD).

5.7.2.7 Internal batteries

Internal batteries shall be so arranged as to minimize risk of electric shock from inadvertent contact with terminals and the interconnection method shall be such as to minimize risk of short-circuiting and electric shock during servicing and replacement.

Compliance with 5.7.2.4 to 5.7.2.7 is checked by inspection.

5.8 Clearances, creepage distances and distances through insulation

The provisions of 2.10/RD apply.

5.9 External signalling circuits

The provisions of 2.3/RD and 2.5/RD apply.

5.10 Limited power source

The provisions of 2.5/RD apply.

6 Wiring, connections and supply

6.1 General

The provisions of 3.1/RD apply.

6.2 Connection to power

The provisions of 3.2.2/RD, 3.2.3/RD, 3.2.4/RD, 3.2.5/RD, 3.2.6/RD, 3.2.7/RD, 3.2.8/RD apply together with the following.

6.2.1 Means of connection

For safe and reliable connection to the **primary power** supply, the **UPS** shall be provided with one of the following:

- terminals for permanent connection to the supply;
- a **non-detachable power supply cord** for permanent connection to the supply, or for connection to the supply by means of a plug;
- an appliance inlet for connection of a **detachable power supply cord**.

Where equipment is provided with more than one supply connection (for example, with different voltages/frequencies or as a redundant power), the design shall be such that all of the following conditions are met:

- separate means of connection are provided for different circuits;
- supply plug connections, if any, are not interchangeable if a hazard could result from incorrect attachment;
- the **operator** is prevented from touching bare parts at ELV or **hazardous voltages**, such as plug contacts, when one or more connectors have been disconnected.

Compliance is checked by inspection.

6.3 Wiring terminals for external power conductors

The provisions of 3.3.1/RD, 3.3.2/RD, 3.3.3/RD, 3.3.4/RD, 3.3.5/RD, 3.3.6/RD, 3.3.7/RD, 3.3.8/RD apply.

7 Physical requirements

The provisions of 4.1/RD apply together with the following.

7.1 Enclosure

The frame or chassis of a unit shall not be used to carry current during intended operation.

NOTE The frames or chassis connected to earth ground can carry leakage currents or current during an electric malfunction.

A part, such as a dial or nameplate that serves as a functional part of the **enclosure** shall comply with the **enclosure** requirements.

Individual modules of a modular unit may be of open construction – either no **enclosure** or partial **enclosure** is supplied – provided that when the modules are assembled together in the field as intended, the unit **enclosure** complies with the requirements in 2.1/RD. Identification of the modules and electrical connections between modules shall comply with clause 3/RD.

The **enclosure** shall protect the various parts of the unit. The parts of an **enclosure** that are required to be in place to comply with the requirements for risk of fire, electric shock, injury to persons and **hazardous energy level** shall comply with the applicable **enclosure** requirements specified in this standard.

Compliance is checked by inspection.

7.2 Stability

The provisions of 4.1/RD apply together with the following.

Under conditions of normal use, units and equipment shall not become physically unstable to the degree that they may become a hazard to **operators** and **service persons**.

If a reliable stabilizing means is used to improve stability when drawers, doors, etc., are opened, it shall be automatic in operation when associated with **operator** use. Where it is not automatic, suitable and conspicuous markings shall be provided to caution **service persons**.

Compliance is checked by the following tests, where relevant. Each test is carried out separately. During the tests, containers shall contain the amount of substance within their rated capacity producing the most disadvantageous condition. Castors, if used in the normal operation of the unit, shall be in their most unfavourable position.

A unit shall not tip over, with or without batteries installed, in whatever represents the most severe conditions outlined in the RD.

7.3 Mechanical strength

The provisions of 4.2/RD apply.

7.4 Construction details

The provisions of 4.3/RD apply together with the following.

7.4.1 Openings

Openings vertically above bare parts at **hazardous voltages** in the top of a **fire enclosure** or an **electrical enclosure** shall not exceed 5 mm in any dimension unless the construction prevents vertical access to such parts, for example, by means of a trap or similar restriction (see figure 4B/RD). This requirement does not apply to equipment having openings in the top of an **enclosure** with a height exceeding 1,8 m.

7.4.2 Gas concentration

Equipment that, in normal use, contains batteries shall incorporate adequate safeguards against the risk of explosive gas concentration and internal or external spillage.

NOTE See also 7.6.

Compliance is checked by inspection.

7.4.3 Equipment movement

Equipment provided with castors to enable easy movement to installed position and intended to have rigid fixed wiring shall have an additional method to ensure the equipment does not move when installed. For a unit having mass of 25 kg or more a force equal to 20 % of the weight of the unit but not more than 250 N is applied to verify that the unit does not move.

Compliance is checked by inspection and test.

7.5 Resistance to fire

The provisions of 4.7/RD apply.

Batteries shall have a **flammability Class HB** or better (see annex A/RD).

7.6 Battery location

Batteries for use with **UPS** require separated or closed locations. They may be designed as

- separate battery rooms or buildings,
- separate cabinets or compartments, indoor or outdoor,
- battery bays or compartments within the **UPS**.

Batteries shall be installed taking into account the following requirements.

Compliance is checked in accordance with 7.6.1 to 7.6.8, as applicable.

7.6.1 Accessibility and maintainability

Battery poles and battery connectors shall be accessible so that their fixings can be tightened with the correct **tools**. Batteries with liquid electrolyte must be so located that the battery cell caps are accessible for electrolyte tests and readjusting of electrolyte levels.

*Compliance is checked by inspection and application of the **tools** and measuring equipment supplied or recommended by the battery manufacturer's conditions.*

7.6.2 Vibration

Protection against vibration shall be provided according to the battery manufacturer's instructions.

Compliance is checked by inspection.

7.6.3 Distance

Battery cells with a casing constructed of insulating material or which are enclosed by an insulating cover, may be mounted without any distance to each other provided the stated ventilation and battery temperature requirements are met.

Compliance is checked by inspection.

7.6.4 Insulation

NiCd cells in conductive casings require adequate insulation between each other and to cabinets or compartments. Such insulation shall meet the requirements of 5.2.

Compliance is checked by test.

7.6.5 Wiring

Contacts, connections and wiring must be protected against effects of ambient temperature, moisture, gas, vapour and mechanical stress according to clause 6.

Compliance is checked by inspection and test.

7.6.6 Electrolyte spillage

Batteries require adequate protection against electrolyte spillage, such as electrolyte resistive coating of battery trays and cabinets.

NOTE This requirement does not apply to VRLA type batteries.

Compliance is checked by inspection.

7.6.7 Ventilation

Proper ventilation shall be provided so that any potential explosive mixtures of hydrogen and oxygen are dispersed safely below hazardous levels.

For battery compartments (separate or combined), the determination method of the necessary airflow to ensure adequate dissolution levels is given in annex N.

In combined apparatus of battery and electrical components, attention shall be given to prevent ignition of local concentrations of hydrogen and oxygen by adjacent operational arcing parts, such as contactors and switches close to battery vents/valves.

This shall be achieved by the use of fully enclosed components or separation of battery compartments or adequate ventilation dependent upon the technical construction of the **UPS** and battery.

The sufficiency of the distance between battery vents/valves and any open arcing component shall be demonstrated by the manufacturer with technical data for the construction of the equipment under test.

For battery rooms proper information on the required flow of air shall be provided in the installation instructions where the battery installation is supplied with the **UPS**.

Compliance is checked by inspection, calculation and measurement. If non-enclosed components are used, a distance of 500 mm between operational arcing parts and the battery vents/valves is normally deemed to meet this requirement.

7.6.8 Charging voltages

Batteries shall be protected against excessive voltages under any single fault condition, for example, due to a charger failure, by switching off the charger or interrupting the charging current. The charging voltage limits shall be as declared by the manufacturer.

Compliance is checked by circuit evaluation and a performance test.

7.7 Temperature rise

The provisions of 4.5.1/RD apply with the following.

Table 2 – Temperature-rise limits

Parts	Maximum temperature rise °C
Insulation, including winding insulation, of	
– Class A material 105	75
– Class E material 120	90
– Class B material 130	95
– Class F material 155	115
– Class H material 180	140
– Class C material 200	150
– Class N material 220	165
– Class P material 240	185

Table 3 – Permitted temperature limits for magnetic windings at the end of stored energy mode operation

Insulation class °C	Temperature by average resistance method °C	Temperature by thermocouple method °C
105	127	117
120	142	132
130	152	142
155	171	161
180	195	185
200	209	199
220	216	206
240	234	224

8 Electrical requirements and simulated abnormal conditions

8.1 General

The provisions of 5.1.1/RD apply together with the following.

8.1.1 Earth leakage current

Where the circuit configuration is such that in any mode of operation the **UPS** protective earth conductor will carry the sum of the **UPS** and connected load earth leakage currents, the **UPS** shall meet the requirements of 5.1.2/RD.

Where the earth leakage current exceeds 3,5 mA, the requirements of 5.1.7/RD shall apply.

Compliance is checked by inspection and by the relevant tests.

8.1.2 Pluggable equipment type B UPS

UPS classified as **pluggable equipment type B** shall have a **non-detachable power supply cord** meeting the requirements of 3.2.5/RD.

Compliance is checked by inspection.

8.2 Electric strength

The provisions of 5.2/RD apply.

8.3 Abnormal operating and fault conditions

The provisions of 5.3.1/RD, 5.3.2/RD, 5.3.3/RD, 5.3.4/RD, 5.3.5/RD, 5.3.8/RD apply together with the following.

8.3.1 Simulation of faults

For components and circuits other than those covered by 5.3.2/RD, 5.3.3/RD and 5.3.5/RD, compliance is checked by simulating the following conditions:

- faults in any components in **primary circuits**;
- faults in any components where failure could adversely affect **supplementary insulation** or **reinforced insulation**;
- additionally, for equipment that does not comply with the requirements of 4.4.2/RD and 4.4.3/RD, faults in all components;
- faults arising from connection of the most unfavourable load impedance to terminals and connectors that deliver power or signal outputs from the equipment, other than main power outlets.

Where there are multiple outlets having the same internal circuitry, the test needs to be made only to one sample outlet.

For components in **primary circuits** associated with the mains input and output, such as the supply cord, appliance couplers, RFI filtering components, **bypass**, switches and their inter-connecting wiring, no fault is simulated, provided that the component complies with 5.3.6 a)/RD.

The equipment, circuit diagrams and component specifications shall be examined to determine those fault conditions that might reasonably be expected to occur.

NOTE Examples are short circuits and open circuits of transistors, diodes and capacitors (particularly the electrolytic capacitors), faults causing continuous dissipation in resistors designed for intermittent dissipation, and internal faults in integrated circuits causing excessive dissipation.

The tests are applied one at a time with the equipment operating at **rated voltage** or at the upper limit of the **rated voltage range**.

It is permitted to test circuits within the equipment, or to test simulated circuits, separate components or sub-assemblies outside the equipment.

In addition to the compliance criteria given in 5.3.3/RD temperatures in the transformer supplying the component under test shall not exceed those specified in annex C/RD and account shall be taken of the exception detailed in such annex.

8.3.2 Conditions for tests

Equipment shall be tested by applying any condition that may be expected in normal use and foreseeable misuse, with the **UPS** operating at **rated voltage** or at the upper limit of the **rated voltage range**.

NOTE Examples of normal use or foreseeable misuse conditions are:

- any operation of accessible operating devices, such as knobs, levers, keys and bars, that is not in accordance with the manufacturer's instructions;
- covering of groups of ventilating openings that are likely to be covered simultaneously, for example, groups of openings situated on one side or on the top of the equipment, such groups to be covered in turn;
- operation under any output overload conditions, including a short circuit.

In addition, equipment that is provided with a protective covering shall be tested with the covering in place under normal idling conditions until steady conditions are established.

9 Connection to telecommunication networks

The provisions of clause 6/RD and the following apply.

1.4.8/RD, 1.4.11/RD, 2.1.1/RD, 2.1.1.1/RD, 2.1.1.2/RD, 2.1.3/RD, 2.3/RD, 2.3.1/RD, 2.3.2/RD, 2.3.3/RD, 2.3.4/RD, 2.3.5/RD, 2.6.1/RD, 2.6.5.8/RD, 2.10.3.3/RD, 2.10.3.4/RD, 2.10.4/RD, 3.5/RD, 3.5.1/RD, 3.5.2/RD, annex M/RD.

Annexes

The following annexes/RD apply.

A (normative) See annex A/RD	Test for resistance to heat and fire
B (normative) See annex B/RD	Motor tests under abnormal conditions
C (normative) See annex C/RD	Transformers
D (normative) See annex D/RD	Measuring instruments for touch-current tests
E (normative) See annex E/RD	Temperature rise of a winding
F (normative) See annex F/RD	Measurements of clearances and creepage distances
G (normative) See G/RD	Alternative method for determining minimum clearances .
J (informative) See annex J/RD	Table of electrochemical potentials
K (normative) See annex K/RD	Thermal controls

In addition, the following annexes apply: H, L, M, N and X.

Annex H (informative)

Guidance on protection against ingress of water and foreign objects

When intended application is such that the ingress of water or foreign objects is possible, an appropriate degree of protection shall be selected from IEC 60529, an extract from which is included in this annex.

It shall not be possible to remove, without the aid of a **tool**, parts that ensure the required degree of protection against ingress of water and foreign objects.

The information in tables H.1 and H.2 is extracted from IEC 60529. For test conditions and compliance, see IEC 60529.

**Table H.1 – Degrees of protection against foreign objects indicated
by the first characteristic numeral**

First characteristic numeral	Degree of protection Brief description	Degree of protection Definition
0	Non-protected	–
1	Protected against solid foreign objects of 50 mm Ø and greater	The object probe, sphere of 50 mm Ø, shall not fully penetrate ^a
2	Protected against solid foreign objects of 12,5 mm Ø and greater	The object probe, sphere of 12,5 mm Ø, shall not fully penetrate ^a
3	Protected against solid foreign objects of 2,5 mm Ø and greater	The object probe, sphere of 2,5 mm Ø, shall not penetrate at all ^a
4	Protected against solid foreign objects of 1,0 mm Ø and greater	The object probe, sphere of 1,0 mm Ø, shall not penetrate at all ^a
5	Dust protected	Ingress of dust is not totally prevented, but dust shall not penetrate in a quantity to interfere with satisfactory operation of the apparatus or to impair safety
6	Dust tight	No ingress of dust

^a The full diameter of the object probe shall not pass through an opening of the **enclosure**.

Table H.2 – Degrees of protection against water indicated by the second characteristic numeral

Second characteristic numeral	Degree of protection Brief description	Degree of protection Definition
0	Non-protected	–
1	Protected against vertically falling water drops	Vertically falling drops shall have no harmful effects
2	Protected against vertically falling water drops when enclosure is tilted up to 15°	Vertically falling drops shall have no harmful effects when the enclosure is tilted at any angle up to 15° on either side of the vertical
3	Protected against spraying water	Water sprayed at an angle up to 60° on either side of the vertical shall have no harmful effects
4	Protected against splashing water	Water splashed against the enclosure from any direction shall have no harmful effects
5	Protected against water jets	Water projected in jets against the enclosure from any direction shall have no harmful effects
6	Protected against powerful water jets	Water projected in powerful jets against the enclosure from any direction shall have no harmful effects
7	Protected against the effects of temporary immersion in water	Ingress of water in quantities causing harmful effects shall not be possible when the enclosure is temporarily immersed in water under standardized conditions of pressure and time
8	Protected against the effects of continuous immersion in water	Ingress of water in quantities causing harmful effects shall not be possible when the enclosure is continuously immersed in water under conditions which shall be agreed between manufacturer and user , but which are more severe than for numeral 7

Annex L (normative)

Backfeed protection test

L.1 General

A **UPS** shall not allow excessive currents to be available between any pairs of input terminals of the **UPS** during its **stored energy mode** of operation. Where the measured open-circuit voltage does not exceed 30 V r.m.s. (42,4 V peak, 60 V d.c.) the measurement need not be taken.

Compliance is checked by circuit analysis, fault testing of components in the control circuitry and the tests in L.2 and L.3.

L.2 Test for pluggable equipment type A or pluggable equipment type B UPS

When the **UPS** is operating in its **stored energy mode**, and with the input terminals or plugs disconnected, the following conditions shall apply for both no-load and full-load conditions.

- a) Under normal and any single-fault conditions, the current shall not exceed 3,5 mA when measured between any two **user** accessible input terminals, using the circuit shown in annex D/RD.
- b) Protection shall operate within 1 s of the disconnection of the input a.c. power supply.

L.3 Test for permanently connected UPS

When the **UPS** is operating in the normal mode with an a.c. power output current in both load and no-load condition and with a single fault applied to the component being investigated, the fault placed on the component shall simulate the failure mode of that component. The a.c. input supply shall then be disconnected and the current is not to exceed 3,5 mA for both normal and single-fault conditions.

Where backfeed protection device is provided externally, the compliance shall be determined by relevant circuit diagram inspection and by operating test of the external backfeed isolator monitoring circuit.

The **UPS** protective conductor shall not be disconnected during the test.

Protection shall operate within 15 s of the disconnection of the input a.c. power supply.

L.4 Single-fault conditions

For the tests in L.2 and L.3, single-fault conditions shall be determined by circuit inspection and investigation, but shall also include potential load faults such as phase-to-earth isolation failures.

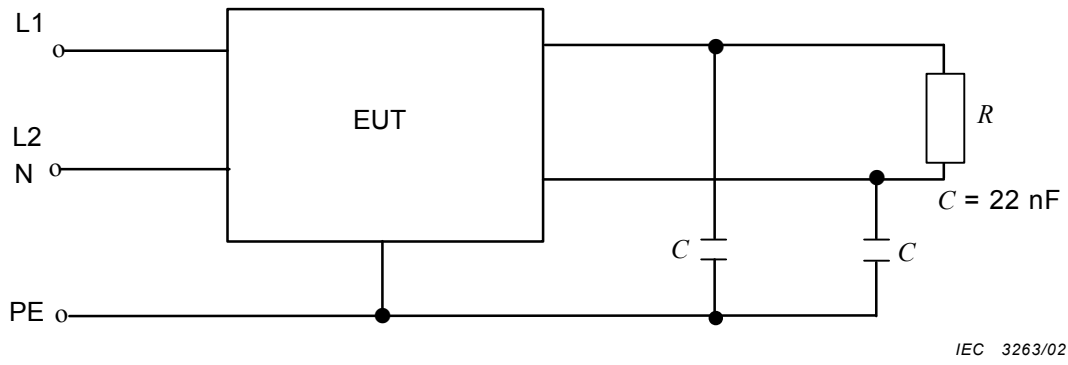

Single-phase output

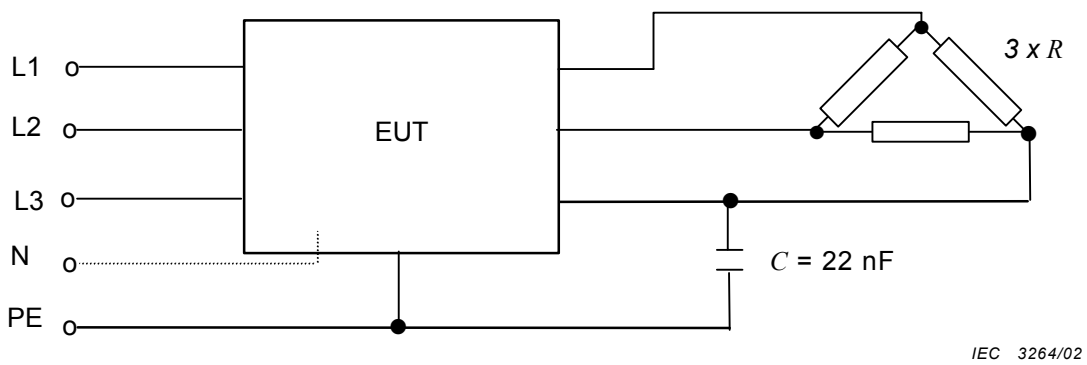

Three-phase output

EUT = Equipment under test

Figure L.1 – Potential load faults

The value of resistive load R shall be equal to that specified as the maximum load at unit power factor by the manufacturer.

Annex M (normative)

Examples of reference load conditions

M.1 General

The **UPS** is loaded according to the manufacturer's specifications given in the instruction manual. If the specifications are missing, the following reference load conditions shall be used.

A **UPS** can be loaded with different **linear** and **non-linear loads** (see 3.3).

A **linear load** is defined by the fact that, with a sinusoidal voltage supplied to such a load, the current will be sinusoidal also.

A **non-linear load** with sinusoidal voltage has non-sinusoidal current.

The most common types of **linear loads** are:

- resistive;
- inductive-resistive;
- capacitive-resistive.

A **non-linear load** could be:

- rectified capacitive load;
- thyristor or transductor controlled load (phase control).

In the low power range < 3 kVA, the rectifier in bridge connection with capacitive load is the most common. The load is characterized by the following symbols:

S = output apparent power in VA

P = output active power in W

λ = power factor = P/S

U = output voltage in V

f = frequency in Hz

M.2 Reference resistive load

For resistive loads, the **UPS** is loaded with a resistor up to nominal power.



IEC 2002/02

$$RL = \frac{U^2}{P}$$

M.3 Reference inductive-resistive load

For inductive-resistive loads, an inductance is connected in series or in parallel with a resistor. The resistor (R) and inductance (L) are given by the following formulae:

a) Series connection

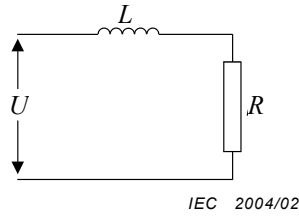

$$R = \frac{U^2}{S} \lambda \quad (\Omega)$$

$$L = \frac{U^2 \sqrt{1 - \lambda^2}}{2\pi f S} \quad (\text{H})$$

b) Parallel connection

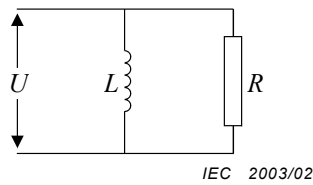

$$R = \frac{U^2}{S \lambda} \quad (\Omega)$$

$$L = \frac{U^2}{2\pi f S \sqrt{1 - \lambda^2}} \quad (\text{H})$$

M.4 Reference capacitive-resistive loads

For capacitive-resistive loads, a capacitance and a resistor are connected either in series or in parallel. The resistor (R) and capacitance (C) are given by the following formulae:

a) Series connection

	$R = \frac{U^2 \lambda}{S} \quad (\Omega)$
	$C = \frac{S}{2\pi f U^2 \sqrt{1 - \lambda^2}} \quad (\text{F})$

b) Parallel connection

	$R = \frac{U^2}{S \lambda} \quad (\Omega)$
	$C = \frac{S \sqrt{1 - \lambda^2}}{2\pi f U^2} \quad (\text{F})$

M.5 Reference non-linear load

To simulate a single-phase steady-state rectifier/capacitor load, the **UPS** is loaded with a diode-rectifier bridge which has a capacitor and a resistor in parallel on its output. The diodes' symbol was the one adopted by IEC 60617-5.

NOTE 1 The following is related to the frequency of 50 Hz to an output voltage distortion of max. 8 % according to IEC 61000-2-2 and to power factor $\lambda = 0,7$ (i.e. 70 % of the apparent power S will be dissipated as active power in the two resistors R_1 and R_S).

The total single-phase load may be formed by a single load or formed by multiple equivalent loads in parallel.

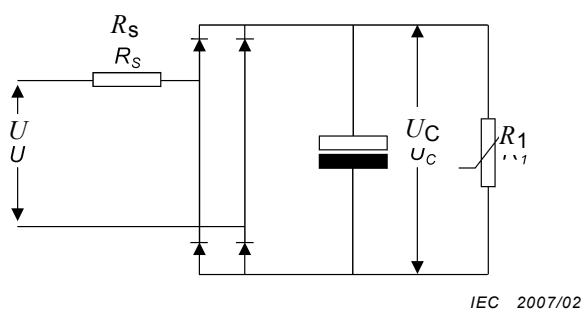

NOTE 2 Resistor R_S can be placed in either the a.c. or d.c. side of the rectifier bridge.

NOTE 3 The actual value of the components used in the test shall be in the range with respect to the calculated values of:

- $R_S = \pm 10\%$
- $R_1 =$ to be adjusted during test to obtain rated output apparent power.
- $C = +25\%$.

U_C is the rectified voltage in V;

R_1 is the load resistor, representing 66 % of active power of the total apparent power S ;

R_S is the serial line resistor, representing 4 % active power of the total apparent power S (the 4 % is according to IEC/TC 64 proposal of voltage drop in power lines).

A ripple voltage, 5 % peak to peak of the capacitor voltage U_C corresponds to a time constant of $R_1 \times C = 0,15$ s.

Observing peak voltage, distortion of line voltage, voltage drop in line cables and ripple voltage of rectified voltage, the average of the rectified voltage U_C will be:

$$U_C = \sqrt{2} \times (0,92 \times 0,96 \times 0,975) \times U = 1,22 \times U$$

and the values of resistors R_S , R_1 and capacitor C will be calculated by the following:

$$R_S = 0,04 \times U^2/S$$

$$R_1 = (U_C)^2/(0,66 \times S)$$

$$C = 0,15 \text{ s} / R_1$$

NOTE 4 The value of capacitor C is valid for 50 Hz and mixed 50 Hz and 60 Hz designs.

M.5.1 Test method

- a) The **non-linear** reference load circuit shall initially be connected to an a.c. input supply at the rated output voltage specified for the **UPS** under test.
- b) The a.c. input supply impedance shall not cause a distortion of the a.c. input waveform greater than 8 % when supplying this reference load (see IEC 61000-2-2).
- c) The resistor R_1 shall be adjusted to obtain the rated output apparent power (S) specified for the **UPS** under test.
- d) After adjustment of resistor R_1 , the **non-linear** reference load shall be applied to the output of the **UPS** under test without further adjustment.
- e) The reference load shall be used, without further adjustment, whilst performing all tests to obtain parameters required under non-linear loading, as defined in the proper clauses.

M.5.2 Connection of the non-linear reference load

- a) For single-phase **UPS**, the non-linear reference load is used with apparent power S equal to the **UPS** rated apparent power up to 33 kVA.
- b) For single-phase **UPS** rated above 33 kVA, the **non-linear load** is used with apparent power S of 33 kVA, plus **linear load** up to the apparent and active power ratings of the **UPS**.
- c) For three-phase **UPS** designed for single-phase loads, equal single-phase **non-linear loads** shall be connected either line-neutral or line-to-line, depending upon the national power system configuration the **UPS** is designed for, up to 100 kVA **UPS** apparent and active power rating.
- d) For three-phase **UPS** rated above 100 kVA, the loads according to clause 3 shall be used, plus **linear load** up to the apparent and active power ratings of the **UPS**.

Annex N (normative)

Ventilation of battery compartments

N.1 General

The **enclosure** or compartment housing a vented battery where gassing is possible during heavy discharge, overcharging, or similar type of usage shall be vented. The means of venting shall provide airflow throughout the compartment in order to reduce the risk of build-up of pressure or accumulation of a gas mixture, such as hydrogen-air, involving a risk of injury to persons.

Arcing parts, such as the contacts of switches, circuit breakers, and relays, shall not be located in the **enclosure** or compartment housing a vented battery, nor shall the **enclosure** or compartment vent into closed spaces where such parts are located. For purposes of this requirement, fuses and connectors do not contain arcing parts. Battery or compartment monitoring sensors (such as temperature sensors and the like) may be located in the **enclosure** or compartment.

If the gas mixture is lighter than air (such as hydrogen-air), the requirement may necessitate locating additional ventilation openings in the uppermost portions of the battery **enclosure** or compartment where such a gas mixture may accumulate.

N.2 Hydrogen concentration

With reference to the above clause, the venting means shall prevent hydrogen concentrations in excess of 4 % by volume. If the adequacy of the ventilation required is not obvious, a determination shall be made by measurement of gas concentration in accordance with the battery compartment ventilation test in N.4. A lead-acid battery at full charge, when most of the charging energy goes into gas, will generate approximately 0,0283 m³ of hydrogen gas per cell for each 63 Ah of input. See N.3.

N.3 Blocked conditions

The ventilating means for an **enclosure** or a compartment housing a battery shall comply with the requirements for blocked fan and blocked filter abnormal conditions.

N.4 Overcharge test

If a measurement is needed to determine if a battery compartment complies with N.2, the battery supply is to be subjected to the overcharge test (see 7.6.8). During, and at the conclusion of the test, the maximum hydrogen gas concentration shall not be more than 2 % by volume; a safety factor of 2 is included. Measurements are to be made by sampling the atmosphere inside the battery compartment at the periods of 2 h, 4 h, 6 h and 7 h during the test. Samples of the atmosphere within the battery compartment are to be taken at the location where the greatest concentration of hydrogen gas is likely, using an aspirator bulb provided with the concentration measurement equipment, or other equivalent means.

When connected to a supply circuit adjusted to 106 % of the **UPS's rated voltage**, a battery supply of a **UPS** is to be subjected to 7 h of overcharging using a fully charged battery. Any user adjustable controls associated with the charger or charging circuit are to be adjusted for the most severe charging rate.

Exception No. 1: This requirement does not apply to a **UPS** to be used with a battery supply that is not tested with the **UPS**.

Exception No. 2: This requirement does not apply to a **UPS** provided with a regulating circuit preventing an increase in battery charging current when the a.c. input voltage is increased from rated value to 106 % of rated value.

Exception No. 3: The formula listed below may be used to comply with the ventilation requirements of this annex.

To allow for equalization (boost charging) and in the case of valve-regulated batteries, operation over a wider range of ambient temperatures the factors of I shall use the 2,4 V/cell figures.

The necessary ventilation air flow for a battery compartment shall be calculated by the following formula:

$$Q = v q s n I C$$

where:

Q is the ventilation air flow, in m³/h;

v is the necessary dilution of hydrogen $(100 - 4)/4 = 24$;

$q = 0,45 \times 10^{-3}$ m³/Ah generated hydrogen;

s is the factor of safety, for example, $s = 5$;

n is the number of battery cells;

$I = 2$ A/100 Ah – conventional flooded cell batteries;

$I = 1$ A/100 Ah – flooded battery cells with low antimony alloy;

$I = 0,5$ A/100 Ah – flooded battery cells with recombination plugs;

$I = 0,2$ A/100 Ah – valve regulated lead-acid batteries;

C is the battery nominal capacity, in Ah at the 10 h discharge rate;

It is permitted to simplify the formula for Q by introducing the resultant value of

$$v q s = 0,054 \text{ m}^3/\text{Ah}.$$

$$Q = 0,054 n I C$$

Q is the air flow, m³/h

This amount of ventilation air flow shall preferably be ensured by natural air flow, otherwise by enforced ventilation.

Inlet and outlet apertures shall allow for a free access of air flow. The mean speed of air shall be in the region of 0,1 m/s.

With this amount of natural air flow, the battery compartment shall contain air inlet and outlet apertures with a free area of $K_1 = 28 \text{ h cm}^2/\text{m}^3$

$$A \geq K_1 Q$$

A is the aperture, in cm^2 ; K_1 : $28 \text{ h cm}^2/\text{m}^3$

or

$$A \geq K_2 n I X$$

$$K_2 = 1,51 \text{ cm}^2/A$$

NOTE 1 Natural ventilation is applicable where the electrical power for hydrogen generation keeps below certain limits. Otherwise the ventilation air outlets would exceed acceptable dimensions. The limits for natural ventilation depend on the battery capacity and the number of cells, and also on the battery technology (vented cells, valve-regulated cells), and the battery charging voltage applied.

The above calculation method will result in a sufficient degree of safety against explosion, assuming hot ($>300 \text{ }^\circ\text{C}$) or sparking components are kept at adequate distance from battery vent plugs or gas pressure outlets. In battery rooms, a distance of 500 mm may be regarded as ensuring sufficient safety. In battery compartments or cabinets or batteries built-in with UPS, it is permitted to reduce this distance depending on the level of ventilation.

The most severe charging rate referred to above is the maximum charging rate that does not cause a thermal or overcurrent protective device to open.

Annex X (informative)

Guidance for disconnection of batteries during shipment

X.1 Applicable products

This informative annex applies to **UPS** and battery cabinets containing internal batteries. Currently the following provisions are for use as a guide only. It may be a normative annex in the future.

X.2 Battery disconnection

Manufacturers should provide a means to disconnect the battery for the purposes of shipment. The means shall be located as close to the battery as possible and before the battery circuit connects to any other electrical devices or circuits, including printed wiring assemblies.

X.3 Package labelling/markings

A precautionary label should be affixed to the shipping carton to alert individuals as to whether the batteries within the package have been disconnected or not.

Manufacturers should use the label shown in figure X.1 for products that have had the battery disconnected prior to shipment.

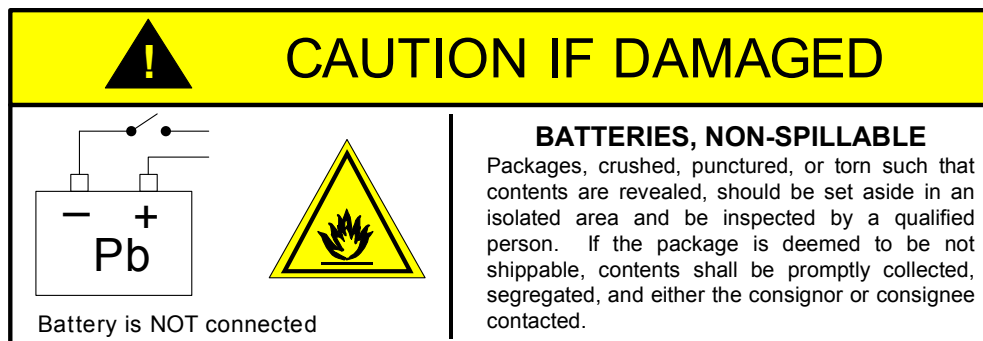

IEC 2008/02

Figure X.1 – Precautionary label for products shipped with the battery disconnected

Manufacturers shall use the label shown in figure X.2 for products that have not had the battery disconnected prior to shipment.

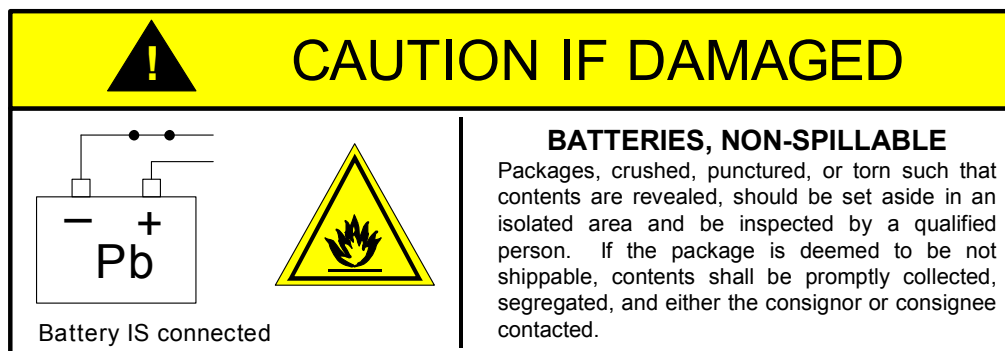

IEC 2009/02

Figure X.2 – Precautionary label for products shipped with the battery connected

NOTE The "Pb" in the battery symbol for figure X.1 and figure X.2 pertains to sealed lead acid batteries. The appropriate chemical symbol shall be substituted for other battery chemistries.

X.4 Damage inspection

Cartons that have been crushed, punctured, or torn in such a way that contents are revealed shall be set aside in an isolated area and inspected by a qualified person. If the package is deemed to be not shippable, the contents shall be promptly collected, segregated, and either the consignor or consignee contacted. Manufacturers should communicate these guidelines to shippers and handlers of the applicable products.

X.5 The importance of safe handling procedures

UPS manufacturers in this programme have conducted comprehensive tests to ensure the equipment they distribute around the world is safe for air transport. Nonetheless, it is important to understand that **UPS** and battery cabinets containing internal batteries can cause fire, smoke or other similar safety hazards if damaged. These products must be handled with care and immediately inspected if visibly damaged.

Annex ZA (normative)

Normative references to international publications with their corresponding European publications

This European Standard incorporates by dated or undated reference, provisions from other publications. These normative references are cited at the appropriate places in the text and the publications are listed hereafter. For dated references, subsequent amendments to or revisions of any of these publications apply to this European Standard only when incorporated in it by amendment or revision. For undated references the latest edition of the publication referred to applies (including amendments).

NOTE When an international publication has been modified by common modifications, indicated by (mod), the relevant EN/HD applies.

<u>Publication</u>	<u>Year</u>	<u>Title</u>	<u>EN/HD</u>	<u>Year</u>
IEC 60417	Series	Graphical symbols for use on equipment	EN 60417	Series
IEC 60529	1989	Degrees of protection provided by enclosures (IP Code)	EN 60529 + corr. May	1991 1993
IEC/TR 60755 A1 A2	1983 1988 1992	General requirements for residual current operated protective devices	-	-
IEC 60950-1 (mod)	2001	Information technology equipment - Safety Part 1: General requirements	EN 60950-1	2001
IEC 61000-2-2	2002	Electromagnetic compatibility (EMC) Part 2-2: Environment - Compatibility levels for low-frequency conducted disturbances and signalling in public low-voltage power supply systems	EN 61000-2-2	2002
IEC 61008-1	1996 ¹⁾	Residual current operated circuit-breakers without integral overcurrent protection for household and similar uses (RCCBs) Part 1: General rules	-	-
IEC 61009-1	1996 ²⁾	Residual current operated circuit-breakers with integral overcurrent protection for household and similar uses (RCBO's) Part 1: General rules	-	-

¹⁾ The European Standard EN 61008-1:1994 (IEC 61008-1:1990 + A1:1992, mod.) + corrigendum December 1997 + A2:1995 (IEC/A2:1995) + A11:1995 + A12:1998 + corrigendum April 1998 + A13:1998 + A14:1998 applies.

²⁾ The European Standard EN 61009-1:1994 (IEC 61009-1:1991, mod.) + corrigendum December 1997 + A1:1995 (IEC/A1:1995) + A11:1995 + A2:1998 + A13:1998 + corrigendum April 1998 + A14:1998 + A15:1998 + A17:1998 applies.

EN 62040-1-1:2003

<u>Publication</u>	<u>Year</u>	<u>Title</u>	<u>EN/HD</u>	<u>Year</u>
IEC 62040-1-2 + corr. December	2002 2002	Uninterruptible power systems (UPS) Part 1-2: General and safety requirements for UPS used in restricted access locations	EN 62040-1-2	2003
IEC 62040-2	1999	Part 2: Electromagnetic compatibility (EMC) requirements	-	-
IEC 62040-3 (mod)	1999	Part 3: Method of specifying the performance and test requirements	EN 62040-3	2001

BSI — British Standards Institution

BSI is the independent national body responsible for preparing British Standards. It presents the UK view on standards in Europe and at the international level. It is incorporated by Royal Charter.

Revisions

British Standards are updated by amendment or revision. Users of British Standards should make sure that they possess the latest amendments or editions.

It is the constant aim of BSI to improve the quality of our products and services. We would be grateful if anyone finding an inaccuracy or ambiguity while using this British Standard would inform the Secretary of the technical committee responsible, the identity of which can be found on the inside front cover. Tel: +44 (0)20 8996 9000. Fax: +44 (0)20 8996 7400.

BSI offers members an individual updating service called PLUS which ensures that subscribers automatically receive the latest editions of standards.

Buying standards

Orders for all BSI, international and foreign standards publications should be addressed to Customer Services. Tel: +44 (0)20 8996 9001. Fax: +44 (0)20 8996 7001. Email: orders@bsi-global.com. Standards are also available from the BSI website at <http://www.bsi-global.com>.

In response to orders for international standards, it is BSI policy to supply the BSI implementation of those that have been published as British Standards, unless otherwise requested.

Information on standards

BSI provides a wide range of information on national, European and international standards through its Library and its Technical Help to Exporters Service. Various BSI electronic information services are also available which give details on all its products and services. Contact the Information Centre. Tel: +44 (0)20 8996 7111. Fax: +44 (0)20 8996 7048. Email: info@bsi-global.com.

Subscribing members of BSI are kept up to date with standards developments and receive substantial discounts on the purchase price of standards. For details of these and other benefits contact Membership Administration. Tel: +44 (0)20 8996 7002. Fax: +44 (0)20 8996 7001. Email: membership@bsi-global.com.

Information regarding online access to British Standards via British Standards Online can be found at <http://www.bsi-global.com/bsonline>.

Further information about BSI is available on the BSI website at <http://www.bsi-global.com>.

Copyright

Copyright subsists in all BSI publications. BSI also holds the copyright, in the UK, of the publications of the international standardization bodies. Except as permitted under the Copyright, Designs and Patents Act 1988 no extract may be reproduced, stored in a retrieval system or transmitted in any form or by any means – electronic, photocopying, recording or otherwise – without prior written permission from BSI.

This does not preclude the free use, in the course of implementing the standard, of necessary details such as symbols, and size, type or grade designations. If these details are to be used for any other purpose than implementation then the prior written permission of BSI must be obtained.

Details and advice can be obtained from the Copyright & Licensing Manager. Tel: +44 (0)20 8996 7070. Fax: +44 (0)20 8996 7553. Email: copyright@bsi-global.com.